

KLINGH-PAK

KP-SWPN Pneumatic Carton Stapler

MANUAL/WARNING:

IMPORTANT PLEASE READ BEFORE USING TOOL

Please read the following operating instructions manual. Refer to this manual for safety, adjustment and trouble shooting instructions. If you have any further questions please contact your distributor.



1320 Tower Road Schaumburg, IL 60173
Phone: 888-392-9947 Fax: 877-393-2948



TABLE OF CONTENTS

	PAGE
TOOL SPECIFICATIONS	4
SAFETY INSTRUCTIONS	5
LUBRICATION AND MAINTENANCE	6
ADJUSTING FOR STAPLE LEG LENGTH	6
CLINCH ADJUSTMENT	7
DEPTH ADJUSTMENT	7
EXPLODED VIEW OF TOOL	8
PARTS LIST	9
TROUBLE SHOOTING	10



TOOL SPECIFICATIONS

MODEL OF TOOLKP-SWPN
DIMENSIONS (LENGTH x HEIGHT x WIDTH) 13" x 4.5" x 8.5"
WEIGHT (WITHOUT FASTENERS) 4.4 lbs

COMPRESSED AIR :

MAXIMUM PERMISSIBLE OPERATING PRESSURE 90 PSI
RECOMMENDED OPERATING PRESSURE..... 71 PSI
AIR CONSUMPTION 0.067 M³ / MIN (2.4 C.F.M)
WITH 60 STAPLES PER MINUTE
@5.66 KG/CM²(80 PSI)
STAPLE SPECIFICATION 1-3/8" CROWN,
LEG LENGTH 5/8", 3/4"
STAPLE CAPACITY 100 PCS (2 Strips)

THE NOISE LEVELS: (AT THE WORKPLACE, ALWAYS WEAR HEARING PROTECTION EQUIPMENT.)

A WEIGHTED SINGLE EVENT SOUND PRESSURE LEVEL AT OPERATOR'S POSITION: **L Pa, 1s = 89 dBA**
A WEIGHTED SINGLE EVENT SOUND POWER LEVEL **L WA, 1s = 93 Dba**
A WEIGHTED SINGLE EVENT SURFACE SOUND PRESSURE LEVEL **L Pa, 1s, 1m = 80 dBA**

KLINGH-PAK

SAFETY INSTRUCTIONS



- Read this manual and understand all safety instructions before operation of the tool. If you have any questions, please contact our Authorized Representatives.



- **Never** allow use of any type of Flammable Gases or Oxygen as a power source for the tool. Use only Filtered, Lubricated, Regulated, Compressed Air.



- **Never** use Gasoline or other Flammable Liquids to clean the tool. Vapors in the tool will ignite by a spark and cause it to explode.



- **Do not exceed** Maximum Permissible Operating Pressure of the tool (90-PSI).



- Disconnect the tool from air supply before clearing jams, servicing, adjusting and during non-operation.



- **Do not** carry the tool by the hose or pull the hose to move the tool.



- Always wear protective equipment such as safety glasses, ear protection and head protection.

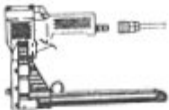

- **Do not** remove the check valve or any other fitting which allows air to remain in the tool.



- **Do not** place your hand or any part of your body in the staple clinching area or adjustment window when connecting or disconnecting the air supply.



- **Never** point any tools that fire projectiles at yourself or another person.

KLINGH-PAK

LUBRICATION AND MAINTENANCE



- Your tool requires lubrication before you use for the **First Time**.

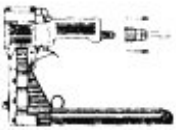

- Disconnect the Air Supply** from the tool before lubricating



- Turn the tool so the inlet is facing up and put one drop of Lubricating Oil into air inlet. **NEVER** use **DETERGENT OIL** or **ADDITIVES**. Operate the tools briefly after adding oil.

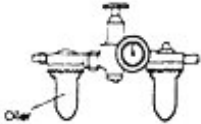

- Wipe off excess oil at the exhaust. Excess oil will damage the O-Rings of the tool (If in-line oiler is used). Manual lubrication through the air inlet is **NOT** required on a daily basis.

ADJUSTING FOR STAPLE LEG LENGTH



- Disconnect the Air Supply**



- Loosen the set screw (526 on Schematic) with a 3 mm Hex Key
- Turn adjusting rod (018 on Schematic) 180 degrees with a flat head screw drive to the desired setting. See diagram A, for positioning explanation.

A.

STAPLES LENGTHS	15MM	18MM
RED POSITION		

- Tighten Set Screw (526) when positioned to desired setting.

KLING-PAK

CLINCH ADJUSTMENT



- **Disconnect the Air Supply**
- Use 3mm Rod or 2.5mm Hex Key to turn the collar (006 on Schematic) found in the front window of the tool. Rotate clockwise for tighter clinch. Counterclockwise for the loose setting. See diagram B.

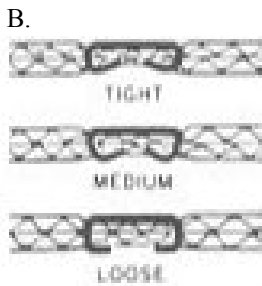

DEPTH ADJUSTMENT



- **Disconnect the Air Supply**
- Loosen the Front Screw (527 on the Schematic) with a 6 mm Hex Key.



- Push the body (007) up and adjust to desired depth.



- When top edge of the adjustment plate (019) is at it's highest setting the teeth are at their shallowest penetration. If set at lowest position, the teeth are at their deepest penetration. See diagram C.

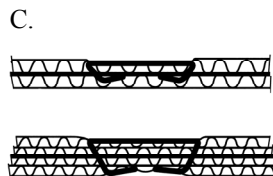

MODEL : KP-SWPN

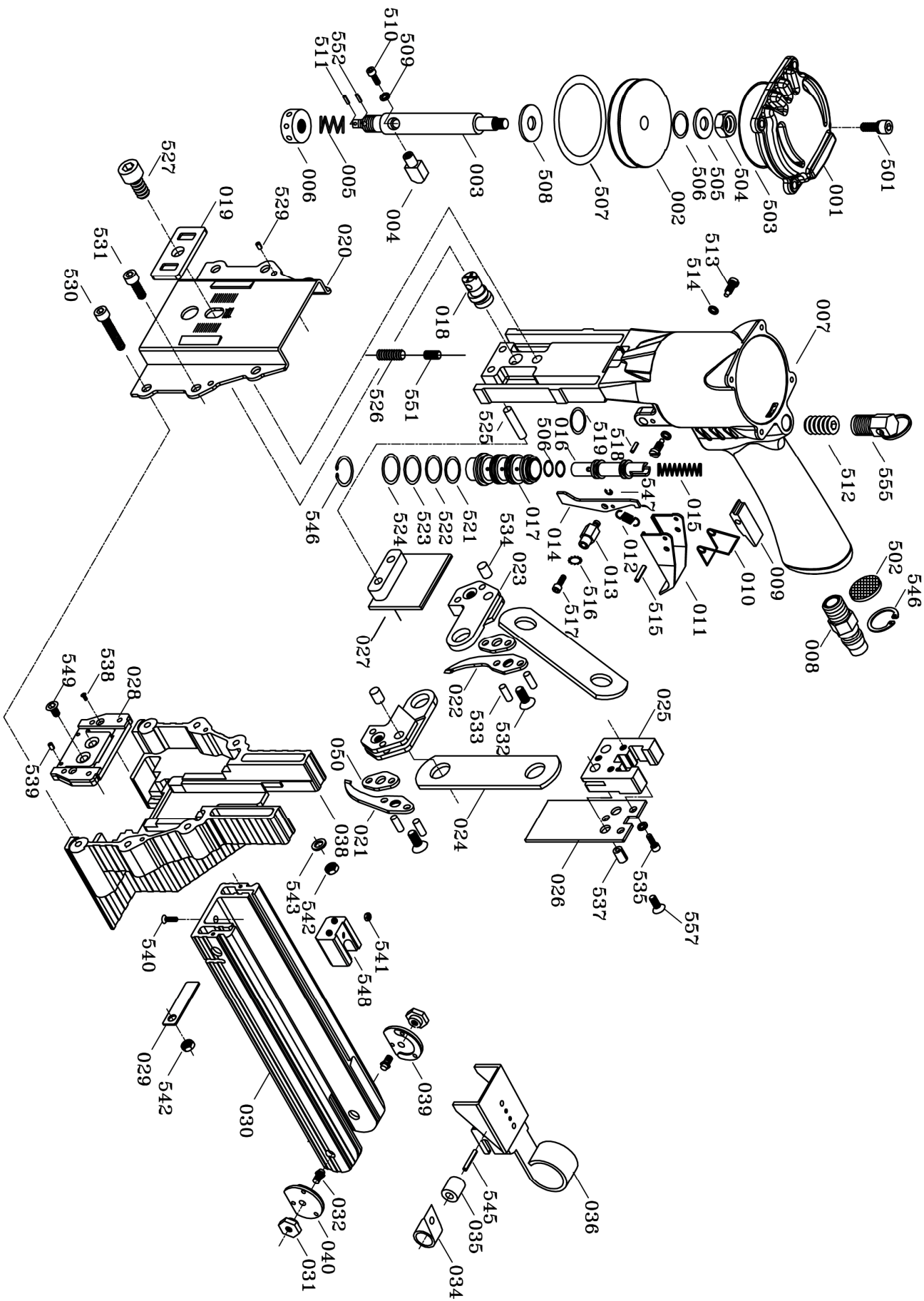

PARTS LIST (KP-SWPN)

*WHEN ORDERING SPARE PARTS, PLEASE STATE ITEM NO., PART NO. AND DESCRIPTION.

ITEM	PART NO	DESCRIPTION	QTY	ITEM	PART NO	DESCRIPTION	QTY	ITEM	PART NO	DESCRIPTION	QTY
001	91000102	CAP	1	036	91203701	PUSHER UNIT	1	532	91007101	FLAT HD.BOLT	2
002	91000201	PISTON	1	038	91003801	MAGAZINE SEAT	1	533	91007201	PIN	4
003	91000301	PISTON ROD	1	039	91003901	RIGHT PUSHER GUIDE	1	534	91007301	PIN	2
004	91000401	BLOCK	1	040	91004001	LEFT PUSHER GUIDE	1	535	91007401	HEX.SOC.HD.BOLT	2
005	91000501	SPRING	1	050	91004101	WASHER	2	537	91007501	SPRING PIN	2
006	91000601	COLLAR	1	501	91004201	HEX.SOC.HD.BOLT	4	538	91007601	FLAT HD.SCREW	2
007	91000701	BODY	1	502	91004301	STIFFENER	1	539	91007701	SPRING PIN	2
008	91000801	AIR PLUG	1	503	91004401	O-RING	1	540	91007801	FLAT HD.BOLT	1
009	91001101	BLOCK	1	504	91004501	HEX.NUT	1	541	91007901	LOCK NUT	1
010	91001201	SPRING	1	505	91004601	WASHER	1	542	91008001	LOCK NUT	6
011	91001301	TRIGGER	1	506	91004701	O-RING	3	543	91008101	WASHER	4
012	91001401	SPRING	1	507	91004801	O-RING	1	545	91008201	SPRING PIN	1
013	91001501	ROD	1	508	91004901	WASHER	1	546	91008301	C-RING	2
014	91001601	TRIGGER 'S CONTROL	1	509	91005001	SPRING WASHER	1	547	91008401	E-RING	1
015	91001701	SPRING	1	510	91005101	HEX.SOC.HD.BOLT	1	548	91008501	BRACKET	1
016	91001801	VALVE	1	511	91005201	SPRING PIN	1	549	91008601	FLAT HD.BOLT	2
017	91001901	TUBE	1	512	91005301	HEX.SOC.HD.LESS.BOLT	1	551	91008701	HELI.COIL	1
018	91002001	ADJUSTING ROD	1	513	91005401	TRIGGER SCREW	2	552	91008801	PLASTIC PIN	1
019	91002101	ADJUSTING PLATE	1	514	91005501	SPRING WASHER	2	555	91008901	COUNTER BALANCER	1
020	91002201	FRONT PLATE	1	515	91005601	SPRING PIN	1	557	91009001	FLAT HD.BOLT	1
021	91002301	RIGHT TEETH	1	516	91005701	OUTSIDE TEETH WASHER	1				
022	91002401	LEFT TEETH	1	517	91005801	HEX.SOC.HD.BOLT	1				
023	91002501	TEETH SEAT	2	518	91005901	SPRING PIN	1				
024	91002601	PLATE	2	519	91006001	O-RING	1				
025	91002701	BLOCK	1	521	91006101	O-RING	1				
026	91002801	DRIVER	1	522	91006201	O-RING	1				
027	91002901	COVER UNIT	1	523	91006301	O-RING	1				
028	91203001	DRIVER GUIDE UNIT	1	524	91006401	O-RING	1				
029	91003101	PLATE	2	525	91006501	ROD	2				
030	91203201	MAGAZINE	1	526	91006601	HEX.SOC.HD.LESS.BOLT	1				
031	91003301	ROD NUT	2	527	91006701	HEX.SOC.HD.BOLT	1				
032	91003401	ROD	2	529	91006801	SPRING PIN	4				
034	91003501	SPRING	1	530	91006901	HEX.SOC.HD.BOLT	2				
035	91003601	ROLLER	1	531	91007001	HEX.SOC.HD.BOLT	4				



TROUBLE SHOOTING

PROBLEM	CAUSE	REMEDY
AIR LEAKAGE FROM TRIGGER .	O-RING ON VALVE (016) OR ON TUBE (017) ARE DAMAGED .	O-RING MUST BE REPLACED
AIR LEAKAGE FROM EXHAUST PORT .	O-RINGSON VALVE (016) OR ON TUBE (017) ARE DAMAGED .	O-RING MUST BE REPLACED
	PISTON'S O-RING (507) IS DAMAGED .	O-RING MUST BE REPLACED
AIR LEAKAGE RROM CYLINDER (004) .	PISTON ROD PORT (007) O-RING (519) IS DAMAGED .	REPLACE THE O-RING .
SLOW AND SHORT TRAVEL CYCLING	CHECK FOR LOOSED SCREW (517) AND WEAR OF PARTS (014,009)	POSITION ECCENTRIC PIN (013) AS SHOWN AND TIGHTEN SCREW (517). IF SHORT TRAVEL OCCURS ADJUST PIN POSITION IN AN UPWARD POSITION. IF SLOW CYCLE ADJUST PIN IN A DOWNWARD DIRECTION.
EXCESSIVE JAMS :	SLOW AND SHORT TRAVEL CYCLING .	CHECK AS NOTED IN SLOW AND SHORT TRAVEL CYCLING SECTION .
	ANVIL SCREWS LOOSE .	TIGHTEN SCREWS
	STAPLE SIZE IS WRONG .	USE THE PROPER SIZE STAPLE
	INSUFFICIENT LUBRICATION	SUITABLY CLEAN AND LUBRICATE
UNEVEN CLINCH	WRONG STAPLE SIZE	CHECK FOR PROPER LEG LENGTH ADJUSTMENT & CLINCHER SIZE .
UNCLINCHED STAPLE	ANVIL (021,022) LOOSE	TIGHTEN ANVIL (021,022)
	ANVIL (021,022) ARE BROKEN	REPLACE ANVIL (021,022)
	SLOW AND SHORT TRAVEL CYCLING .	CHECK AS NOTED IN SLOW AND SHORT TRAVEL CYCLING SECTION .

Products offered by



KLINGH-PAK

COMPLETE

APACH

Rapid ®

Call today for more details

Visit our web site
www.axxisus.com

Or

Email us @
reception.inc@axxisus.com



1320 Tower Road Schaumburg, IL 60173
Phone: 888-392-9947 Fax: 877-393-2948